

# luxcambra

## Oita a

Applique Wall lamp Applique

E-27 LED 12 W  
LED 2 W  
150 lm / 2.700 K

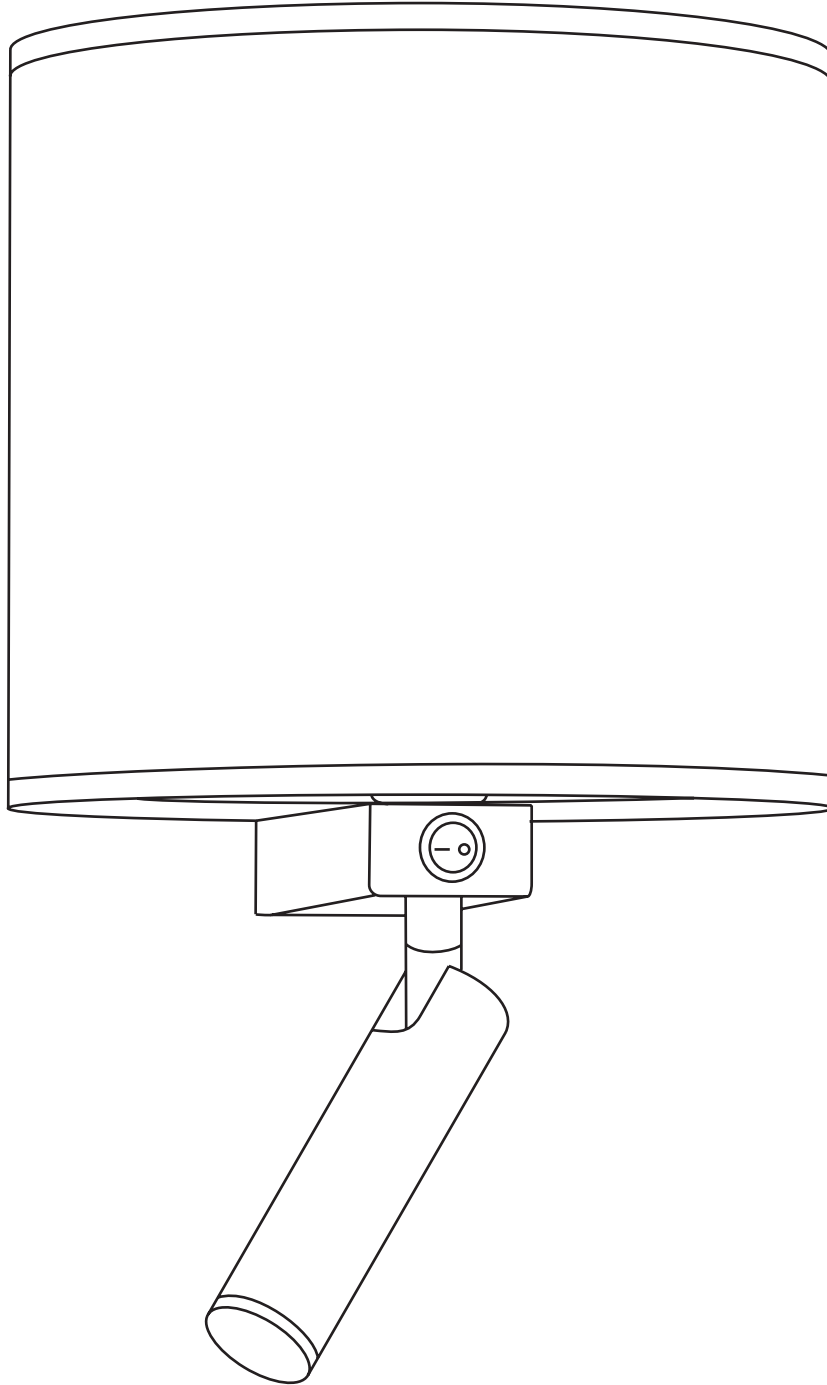

# Oita a

Applique Wall lamp Applique

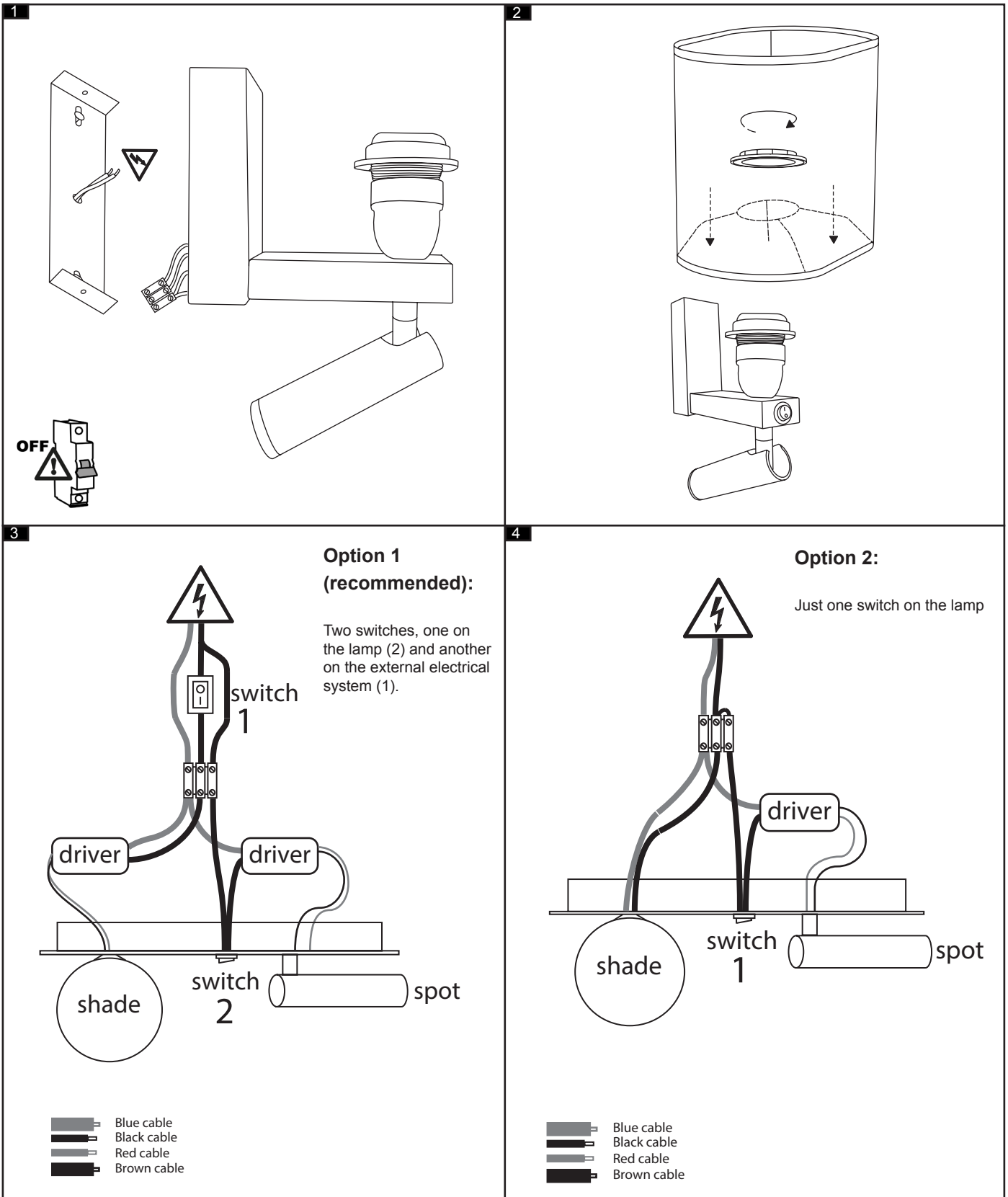

# Oita a

Applique *Wall lamp* Applique

---

